

Description

The SLVU2.8-4BTG is designed to protect voltage sensitive components from ESD and transient voltage events. Excellent clamping capability, low leakage, and fast response time. The SLVU2.8-4BTG is suited for using in 10/100/1000M Ethernet.

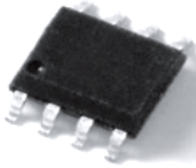

Features

- ◆ IEC 61000-4-2 (ESD)
 - ±30kV Contact Discharge
 - ±30kV Air Discharge
- ◆ IEC 61000-4-5 (Lightning)
 - 30A (8/20us)
- ◆ IEC 61000-4-4 EFT Protection
 - 40A (5/50ns)
- ◆ Halogen free and RoHS compliant
- ◆ Protects 4 channels I/O line
- ◆ Transient protection for high-speed data lines
- ◆ Low clamping voltage
- ◆ Low leakage current

Mechanical Characteristics

- ◆ SO-8
- ◆ ROHS/ Compliant
- ◆ Halogen free
- ◆ Molding compound flammability rating: UL 94V-0
- ◆ Marking: Part number
- ◆ Packing: Tape and Reel per EIA 481

Applications

- ◆ Base station
- ◆ 10/100/1000M Ethernet
- ◆ WAN/LAN equipment
- ◆ Desktop/Notebooks/Servers
- ◆ Low voltage interfaces

Pin Configuration

Marking	Outline	Circuit Diagram

Ordering Information

Part Number	Package	Marking	Packing	Reel Size
SLVU2.8-4BTG	SO-8	See above showed	2500/Tape & Reel	13 inch

Absolute Maximum Ratings ($T_A=25^\circ\text{C}$ unless otherwise specified)

Parameters	Symbol	Min.	Max.	Unit
Peak pulse power ($t_p=8/20\mu\text{s}$)@ 25°C	P_{pk}	-	600	W
Peak pulse current ($t_p=8/20\mu\text{s}$)@ 25°C	I_{pp}	-	30	A
ESD (IEC61000-4-2 air discharge) @ 25°C	V_{ESD}	-	± 30	kV
ESD (IEC61000-4-2 contact discharge) @ 25°C	V_{ESD}	-	± 30	kV
Junction temperature	T_J	-	125	$^\circ\text{C}$
Operating temperature	T_{OP}	-55	125	$^\circ\text{C}$
Storage temperature	T_{STG}	-55	150	$^\circ\text{C}$
Lead temperature	T_L	-	260	$^\circ\text{C}$

Electrical Characteristics ($T_A=25^\circ\text{C}$ unless otherwise specified)

Parameter	Symbol	Conditions	Min.	Typ.	Max.	Units
Reverse Stand-off Voltage	V_{RWM}				2.8	V
Pouch-Through Voltage	VPT	2uA	3.0			
Snap-Back Voltage	V_{BR}	$I_{sb}=50\text{mA}$	2.8			V
Reverse Leakage Current	I_R	$V_{RWM}=2.8\text{V}$ each line		0.1	1	μA
Clamping Voltage	V_C	$I_{pp}=1\text{A}$; $t_p=8/20\mu\text{s}$			6	V
Clamping Voltage	V_C	$I_{pp}=5\text{A}$; $t_p=8/20\mu\text{s}$			8	V
Clamping Voltage	V_C	$I_{pp}=10\text{A}$; $t_p=8/20\mu\text{s}$			10	V
Clamping Voltage	V_C	$I_{pp}=30\text{A}$; $t_p=8/20\mu\text{s}$			20	V
Junction Capacitance	C_J	Each line; $V_R=0\text{V}$; $f=1\text{MHz}$		2		pF



Typical Performance Characteristics ($T_A=25^\circ\text{C}$ unless otherwise Specified)

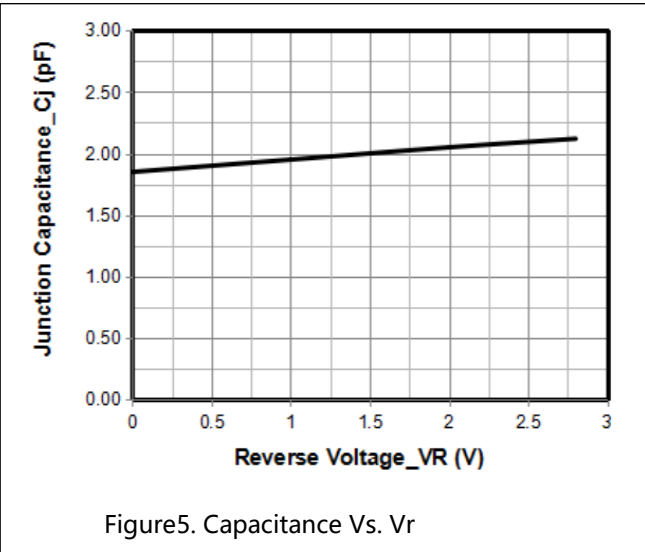
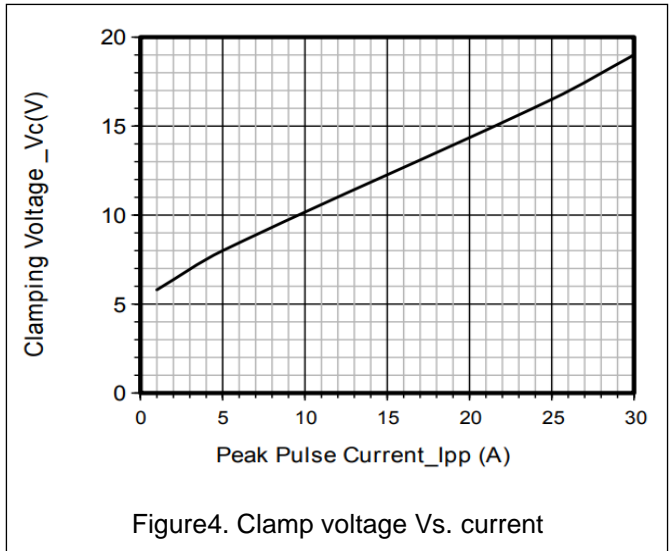
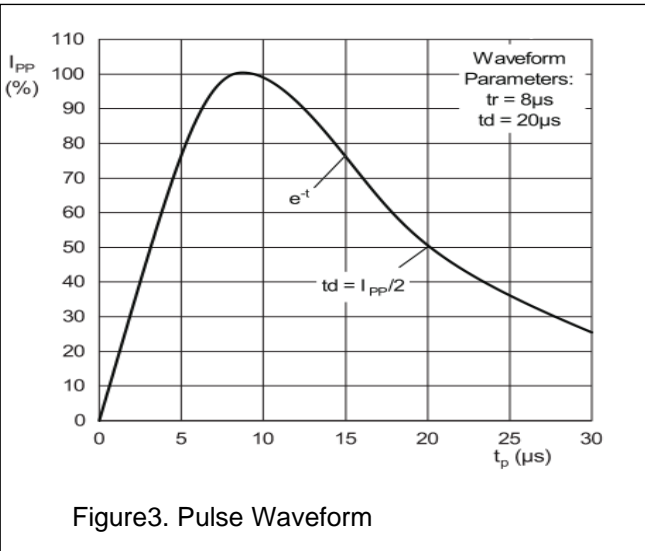
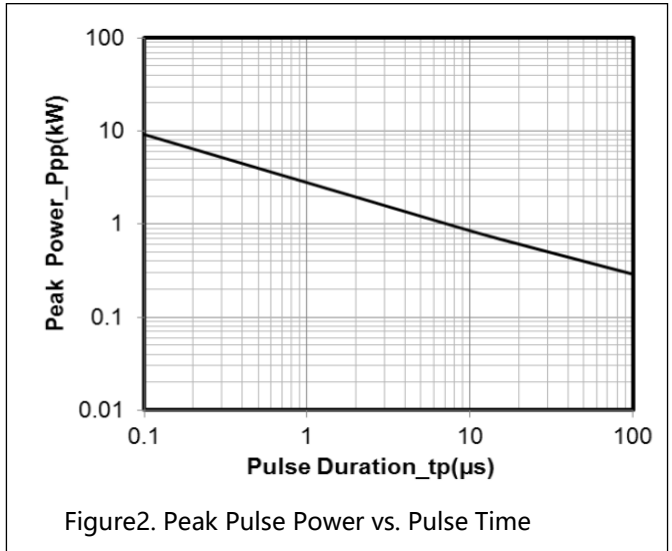
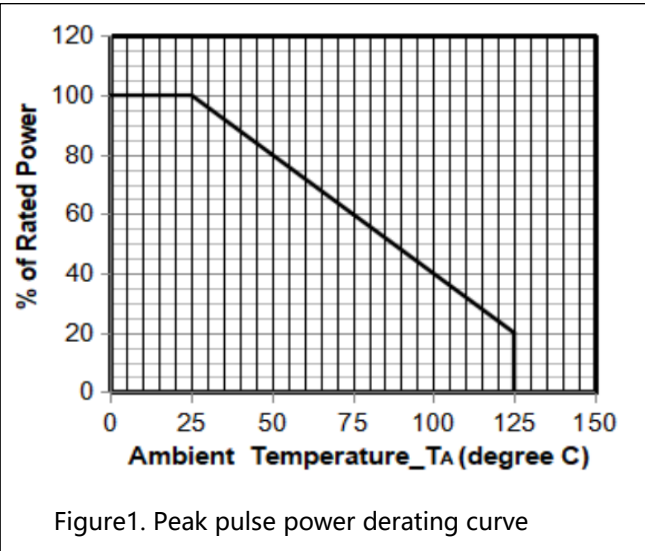

Applications Information

Typical Ethernet application

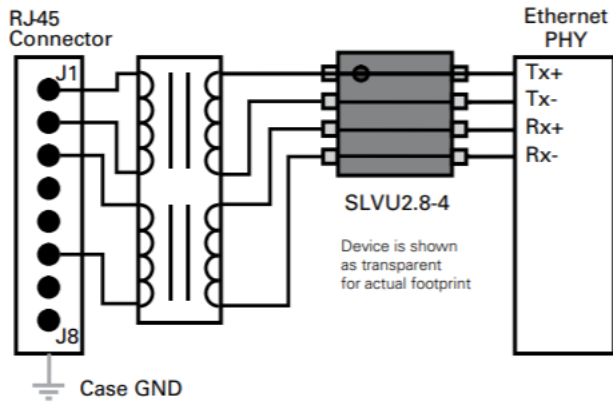

Package Outline Drawing

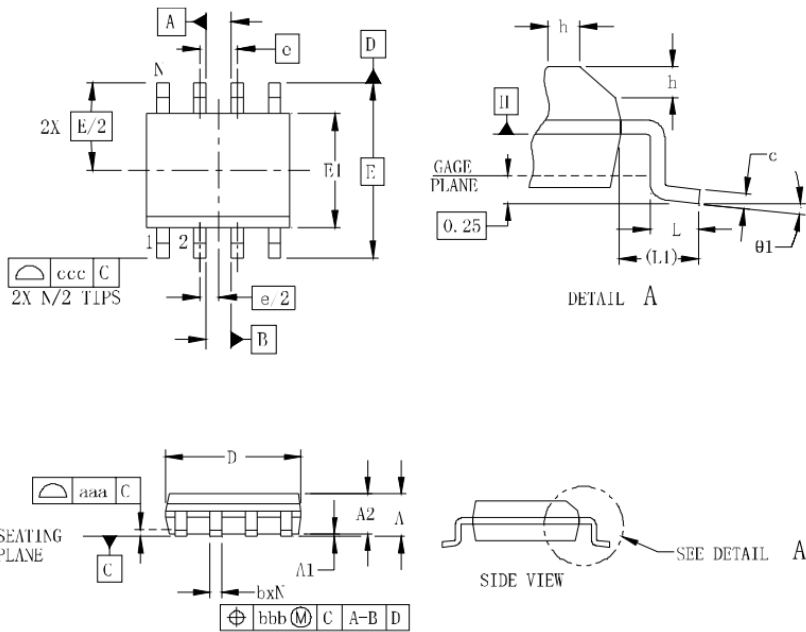

SYM	DIMENSIONS					
	MILLIMETERS			INCHES		
	MIN	NOM	MAX	MIN	NOM	MAX
A	1.35		1.75	0.053		0.069
A1	0.10		0.25	0.004		0.010
A2	1.25		1.65	0.049		0.065
b	0.31		0.51	0.012		0.020
c	0.17		0.25	0.007		0.010
D	4.80	4.90	5.00	0.189	0.193	0.197
E1	3.80	3.90	4.00	0.150	0.154	0.157
E	6.00 BSC			0.236 BSC		
e	1.27 BSC			0.050 BSC		
h	0.25		0.50	0.010		0.020
L	0.40	0.72	1.04	0.016	0.028	0.041
L1	(1.04)			(0.041)		
N	8			8		
θ1	0°		8°	0°		8°
aaa	0.10			0.004		
bbb	0.25			0.010		
ccc	0.20			0.008		

Recommended Land Pattern

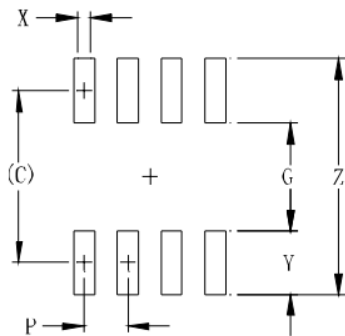

SYM	DIMENSIONS	
	MILLIMETERS	INCHES
C	(5.20)	0.205
G	3.00	0.118
P	1.27	0.050
X	0.60	0.024
Y	2.20	0.087
Z	7.40	0.291

Revision history of Specification

Version	Change Items	Effective Date
1.0	Initial Release	13-Aug-2021